



標準螺絲供應有限公司 (513831-P)  
**STANDARD BOLTS & NUTS SDN. BHD.**

No. 47 & 49, Jalan TPP 1/1, Taman Industri Puchong, 12th Miles,  
 47100 Puchong, Selangor Darul Ehsan, Malaysia.

Tel: 03-8062 3811 (Hunting Line)

Fax: 03-8062 2230, 8068 2811

Website: <http://www.standardbolts.net>

E-mail: [sale@standardbolts.net](mailto:sale@standardbolts.net)



# GREASE NIPPLE 45 DEGREE TYPE



**Material**  
 Steel

**Finishing**  
 Steel comes in Nickel Plated Finishing

Thread Size (D1)	M6	M8	M10			
Thread Pitch	1.0	1.0	1.0			
Head Dia. (D2)	6.5MM	6.5MM	6.5MM			
A/F	8MM	10MM	11MM			
H1	17MM	19MM	20MM			
H2	15MM	15MM	16MM			
Thread (T)	6MM	7MM	8MM			

Thread Size (D1)	1/8	1/4	1/4	5/16	3/8	1/2
Thread	BSP	BSP	UNF	UNF	UNF	UNF
Head Dia. (D2)	6.5MM	6.5MM	6.5MM	6.5MM	6.5MM	6.5MM
A/F	10MM	14MM	8MM	10MM	10MM	14MM
H1	20MM	23.5MM	17MM	19MM	20MM	23MM
H2	15MM	17MM	14MM	15MM	15MM	18MM
Thread (T)	8MM	9MM	6MM	7MM	8MM	9MM

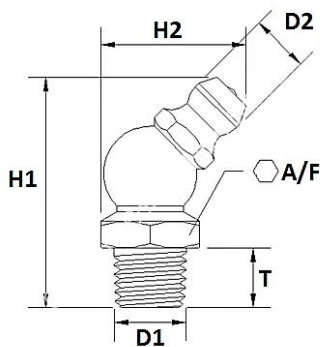

**BRANCH :**

**SBN (KLANG)**

135 & 137, Jalan Batu Tiga Lama,  
 Berkeley Town Centre,  
 41300 Klang, Selangor Darul Ehsan.  
 Tel : 03-3344 1198 (Hunting Line)  
 Fax : 03-3344 2811  
 E-mail: [sbnk@standardbolts.net](mailto:sbnk@standardbolts.net)

**SBN (SG. BULOH)**

No. 5 & 7, Block D, Jalan Gelen J, U19/J,  
 Megamas Business Centre, Kampung Baru Sg. Buloh,  
 47000 Sg. Buloh, Selangor Darul Ehsan, Malaysia.  
 Tel : 03-6148 1198 (Hunting Line)  
 Fax : 03-6148 2811  
 E-mail: [sbnsb@standardbolts.net](mailto:sbnsb@standardbolts.net)