



標準螺絲供應有限公司 (513831-P) STANDARD BOLTS & NUTS SDN. BHD.

No. 47 & 49, Jalan TPP 1/1, Taman Industri Puchong, 12th Miles,
47100 Puchong, Selangor Darul Ehsan, Malaysia.

Tel: 03-8062 3811 (Hunting Line)

Website: <http://www.standardbolts.net>

Fax: 03-8062 2230, 8068 2811

E-mail: sale@standardbolts.net



THREAD INSERT (MM SIZE)

Material

Stainless Steel 304 (A2)

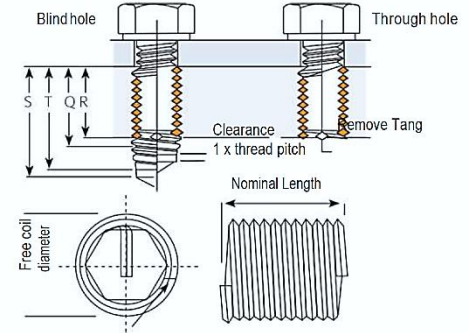

Specifications for Drilling, Tapping and Installation Depths

Drill Depth:
The minimum drilling depth "S" allows for one pitch chip clearance between the tip of the tap and the bottom of the drilled hole.
"S" minimum allows for tap clearance, the maximum amount of insert set-down and countersink. Where a spiral pointed tap is used, the drill depths shown should be increased to allow for chip clearance.

Fitted Insert:
R = Maximum length of engaged portion of screw when tang is removed.
Q = Minimum full tapped thread length.
T = Minimum tapping depth - including 3 1/2 threads of plug tap. S = Minimum drill depth - excluding point.

Note: Recoil metric inserts are made to Din locking torque requirements. Military specification MA parts need to be specifically ordered by adding MA to the standard part number above.
Note: Dimensions shown are for MA parts only.

Thread Size	1.0D				1.5D				2.0D				2.5D				3.0D			
	Q	R	S	T	Q	R	S	T	Q	R	S	T	Q	R	S	T	Q	R	S	T
M2 X 0.4	2.00	1.60	3.80	3.40	3.00	2.60	4.80	4.40	4.00	3.60	5.80	5.40	5.00	4.60	6.80	6.40	6.00	5.60	7.00	7.40
M2.2 X 0.45	2.20	1.75	4.23	3.98	3.30	2.85	5.33	4.88	4.40	3.95	6.43	5.98	5.50	5.05	7.53	7.08	6.60	6.15	8.63	8.18
M2.5 X 0.45	2.50	2.05	4.53	4.08	3.75	3.3	5.78	5.33	5.00	4.55	7.03	6.58	6.25	5.80	8.28	7.83	7.50	7.05	9.53	9.08
M3 X 0.5	3.00	2.50	5.25	4.75	4.50	4.00	6.75	6.25	6.00	5.50	8.25	7.75	7.50	7.00	9.75	9.25	9.00	8.50	11.25	10.75
M3.5 X 0.6	3.50	2.90	6.20	5.60	5.25	4.65	7.95	7.35	7.00	6.40	9.70	9.10	8.75	8.15	11.45	10.85	10.50	9.90	13.20	12.60
M4 X 0.7	4.00	3.30	7.15	6.45	6.00	5.30	9.15	8.45	8.00	7.30	11.15	10.45	10.00	9.30	13.15	12.45	12.00	11.30	15.15	14.45
M4.5 X 0.75	4.50	3.75	7.88	7.13	6.75	6.00	10.13	9.38	9.00	8.25	12.38	11.63	11.25	10.50	14.63	13.88	13.50	12.75	16.88	16.13
M5 X 0.8	5.00	4.20	8.60	7.80	7.50	6.70	11.10	10.30	10.00	9.20	13.60	12.80	12.50	11.70	16.10	15.30	15.00	14.20	18.60	17.80
M6 X 1.0	6.00	5.00	10.50	9.50	9.00	8.00	13.50	12.50	12.00	11.00	16.50	15.50	15.00	14.00	19.50	18.50	18.00	17.00	22.50	21.50
M7 X 1.0	7.00	6.00	11.50	10.50	10.50	9.50	15.00	14.00	14.00	13.00	18.50	17.50	17.50	16.50	22.00	21.00	21.00	20.00	25.50	24.50
M8 X 1.0	8.00	7.00	12.50	11.50	12.00	11.00	16.50	15.50	16.00	15.00	20.50	19.50	20.00	19.00	24.50	23.50	24.00	23.00	28.50	27.50
M8 X 1.25	8.00	6.75	13.63	12.38	12.00	10.75	17.63	16.38	16.00	14.75	21.63	20.38	20.00	18.75	25.63	24.38	24.00	22.75	29.63	28.38
M9 X 1.25	9.00	7.75	14.63	13.38	13.50	12.25	19.13	17.88	18.00	16.75	23.63	22.38	22.50	21.25	28.13	26.88	27.00	25.75	32.63	31.38
M10 X 1.25	10.00	8.75	15.63	14.38	15.00	13.75	20.63	19.38	20.00	18.75	25.63	24.38	25.00	23.75	30.63	29.38	30.00	28.75	35.63	34.38
M10 X 1.5	10.00	8.50	16.75	15.25	15.00	13.50	21.75	20.25	20.00	18.50	26.75	25.25	25.00	23.50	31.75	30.25	30.00	28.50	36.75	35.25
M11 X 1.5	11.00	9.50	17.75	16.25	16.50	15.00	23.25	21.75	22.00	20.50	28.75	27.25	27.50	26.00	34.25	32.75	33.00	31.50	39.75	38.25
M12 X 1.25	12.00	10.75	17.63	16.38	18.00	16.75	23.63	22.38	24.00	22.75	29.63	27.38	30.00	28.75	35.63	34.38	36.00	34.75	41.63	40.38
M12 X 1.5	12.00	10.50	18.75	17.25	18.00	16.50	24.75	23.25	24.00	22.50	30.75	29.25	30.00	28.50	36.75	32.25	36.00	34.50	42.75	41.25
M12 X 1.75	12.00	10.25	19.88	18.13	18.00	16.25	25.88	24.13	24.00	22.25	31.88	30.13	30.00	28.25	37.88	36.13	36.00	34.25	43.88	42.13
M14 X 1.5	14.00	12.50	20.75	19.25	21.00	19.50	27.75	26.25	28.00	26.50	34.75	33.25	35.00	33.50	41.75	40.25	42.00	40.50	48.75	47.25
M14 X 2.0	14.00	12.00	23.00	21.00	21.00	19.00	30.00	28.00	28.00	26.00	37.00	35.00	35.00	33.00	44.00	42.00	42.00	40.00	51.00	49.00
M16 X 1.5	16.00	14.50	22.75	21.25	24.00	22.50	30.75	29.25	32.00	30.50	38.75	37.25	40.00	38.50	46.75	45.25	48.00	46.50	54.75	53.25
M16 X 2.0	16.00	14.00	25.00	23.00	24.00	22.00	33.00	31.00	32.00	30.00	41.00	39.00	40.00	38.00	49.00	47.00	48.00	46.00	57.00	55.00
M18 X 1.5	18.00	16.50	24.75	23.25	27.00	25.50	33.75	32.25	36.00	34.50	42.75	41.25	45.00	43.50	51.75	50.25	54.00	52.50	60.75	59.25
M18 X 2.0	18.00	16.00	27.00	25.00	27.00	25.00	36.00	34.00	36.00	34.00	45.00	43.00	45.00	43.00	54.00	52.00	54.00	52.00	63.00	61.00
M18 X 2.5	18.00	15.50	29.25	26.75	27.00	24.50	38.25	35.75	36.00	33.50	47.25	44.75	45.00	42.50	56.25	53.75	54.00	51.50	65.25	62.75

SBN Klang (Branch)

Standard Bolts & Nuts (Klang) Sdn Bhd
No. 135 & 137, Jalan Batu Tiga Lama,
Berkeley Town center, 41300 Klang,
Selangor Darul Ehsan, Malaysia
Tel: 03-3344 1198 (Hunting Line)
Fax: 03-3344 2811
Email: sbnk@standardbolts.net

SBN Sg Buloh (Branch)

Standard Bolts & Nuts (Sg. Buloh) Sdn Bhd
NO.5 & 7, Block D, Jalan Gelen J, U19/J,
Megamas Business Centre, Kg Baru Sg. Buloh,
47000 Sg. Buloh, Selangor Darul Ehsan, Malaysia
Tel: 03-6148 1198 (Hunting Line)
Fax: 03-6148 2811
Email: sbnsb@standardbolts.net

SBN Johor (Branch)

Standard Bolts & Nuts Supply Sdn Bhd
No. 12 & 14, Jalan Ros Merah 2/17,
Taman Johor Jaya,
81100 Johor Bahru, Johor.
Tel: 07-358 3221 (Hunting Line)
Fax: 07-364 9279
Email: sbnjb@standardbolts.net



標準螺絲供應有限公司 (513831-P) STANDARD BOLTS & NUTS SDN. BHD.

No. 47 & 49, Jalan TPP 1/1, Taman Industri Puchong, 12th Miles,
47100 Puchong, Selangor Darul Ehsan, Malaysia.

Tel: 03-8062 3811 (Hunting Line)
Website: <http://www.standardbolts.net>

Fax: 03-8062 2230, 8068 2811
E-mail: sale@standardbolts.net



THREAD INSERT (MM SIZE)

Material

Stainless Steel 304 (A2)

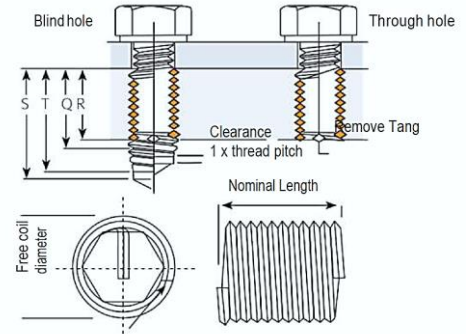

Specifications for Drilling, Tapping and Installation Depths

Drill Depth:
The minimum drilling depth "S" allows for one pitch chip clearance between the tip of the tap and the bottom of the drilled hole.
"S" minimum allows for tap clearance, the maximum amount of insert set-down and countersink. Where a spiral pointed tap is used, the drill depths shown should be increased to allow for chip clearance.

Fitted Insert:
R = Maximum length of engaged portion of screw when tang is removed.
Q = Minimum full tapped thread length.
T = Minimum tapping depth - including 3 1/2 threads of plug tap. S = Minimum drill depth - excluding point.
Note: Recoil metric inserts are made to Din locking torque requirements. Military specification MA parts need to be specifically ordered by adding MA to the standard part number above.
Note: Dimensions shown are for MA parts only.

Thread Size	1.0D				1.5D				2.0D				2.5D				3.0D			
	Q	R	S	T	Q	R	S	T	Q	R	S	T	Q	R	S	T	Q	R	S	T
M20 X 1.5	20.00	18.50	26.75	25.25	30.00	28.50	36.75	35.25	40.00	38.50	46.75	45.25	50.00	48.50	56.75	55.25	60.00	58.50	66.75	65.25
M20 X 2.0	20.00	18.00	29.00	27.00	30.00	28.00	39.00	37.00	40.00	38.00	49.00	47.00	50.00	48.00	59.00	57.00	60.00	58.00	69.00	67.00
M20 X 2.5	20.00	17.50	31.25	28.75	30.00	27.50	41.25	38.75	40.00	37.50	51.25	48.75	50.00	47.50	61.25	58.75	60.00	57.50	71.25	68.75
M22 X 1.5	22.00	20.50	28.75	27.25	33.00	31.50	39.75	38.25	44.00	42.50	50.75	49.25	55.00	53.50	61.75	60.25	66.00	64.50	72.75	71.25
M22 X 2.0	22.00	20.00	31.00	29.00	33.00	31.00	42.00	40.00	44.00	42.00	53.00	51.00	55.00	53.00	64.00	62.00	66.00	64.00	75.00	73.00
M22 X 2.5	22.00	19.50	33.25	30.75	33.00	30.50	44.25	41.75	44.00	41.50	55.25	52.75	55.00	52.50	66.25	63.75	66.00	63.50	77.25	74.75
M24 X 2.0	24.00	22.00	33.00	31.00	36.00	34.00	45.00	43.00	48.00	46.00	57.00	55.00	60.00	58.00	69.00	67.00	72.00	70.00	81.00	79.00
M24 X 3.0	24.00	21.00	37.50	34.50	36.00	33.00	49.50	46.50	48.00	45.00	61.50	58.50	60.00	57.00	73.50	70.50	72.00	69.00	85.50	82.50
M27 X 3.0	27.00	24.00	40.50	37.50	40.50	37.50	54.00	51.00	54.00	51.00	67.50	64.50	67.50	64.50	81.00	78.00	81.00	78.00	94.50	91.50
M30 X 3.5	30.00	26.50	45.75	42.25	45.00	41.50	60.75	57.25	60.00	56.50	75.75	72.25	75.00	71.50	90.75	87.25	90.00	86.50	105.75	102.25
M33 X 3.5	33.00	29.50	48.75	45.25	49.50	46.00	65.25	61.75	66.00	62.50	81.75	78.25	82.50	79.00	98.25	94.75	99.00	95.50	114.75	111.25
M36 X 4.0	36.00	32.00	54.00	50.00	54.00	50.00	72.00	68.00	72.00	68.00	90.00	86.00	90.00	86.00	108.00	104.00	108.00	104.00	126.00	122.00
M39 X 4.0	39.00	35.00	57.00	53.00	58.50	54.50	76.50	72.50	78.00	74.00	96.00	92.00	97.50	93.50	115.50	111.50	117.00	113.00	135.00	131.00

SBN Klang (Branch)

Standard Bolts & Nuts (Klang) Sdn Bhd
No. 135 & 137, Jalan Batu Tiga Lama,
Berkeley Town center, 41300 Klang,
Selangor Darul Ehsan, Malaysia
Tel: 03-3344 1198 (Hunting Line)
Fax: 03-3344 2811
Email: sbnk@standardbolts.net

SBN Sg Buloh (Branch)

Standard Bolts & Nuts (Sg. Buloh) Sdn Bhd
NO.5 & 7, Block D, Jalan Gelen J, U19/J,
Megamas Business Centre, Kg Baru Sg. Buloh,
47000 Sg. Buloh, Selangor Darul Ehsan, Malaysia
Tel: 03-6148 1198 (Hunting Line)
Fax: 03-6148 2811
Email: sbnsb@standardbolts.net

SBN Johor (Branch)

Standard Bolts & Nuts Supply Sdn Bhd
No. 12 & 14, Jalan Ros Merah 2/17,
Taman Johor Jaya,
81100 Johor Bahru, Johor.
Tel: 07-358 3221 (Hunting Line)
Fax: 07-364 9279
Email: sbnjb@standardbolts.net